



Date 16.05.2022r.

APPLICATION MANUAL

Flameproof Ex d connection head

Type: **XD-SD...** , **XD-SH...** , **XD-SB...**

XD-SDwin , **XD-SHwin** , **XD-SBwin Series**

Flameproof Ex d field transmitter housing

Type: **XD-SDF...** , **XD-SHF...** , **XD-SBF...**

XD-SDFwin , **XD-SHFwin** , **XD-SBFwin Series**

Contents:

1. Variety marks and cover body fitting
2. Destination.
3. Flameproof joints.
4. Flameproof joints on D_1 / d_1 holes.
5. Carried out tests.
6. Conduit opening: D_2, D_3 .
7. Temperature classes, ambient temperature, power dissipation.
8. Earth and protection terminals.
9. Maximum space for transmitter and display module.
10. Protection degree.
11. Cover locking.
12. Way of fixing field transmitter housing to the wall and on the pipe.
13. Marking.

NOTES OF SAFETY

The **XD-S...** connection head, and **XD-S...F...** field transmitter housing are designed to accommodate various electronic instruments. If used incorrectly it is possible that application-related dangers may arise.

The **XD-S...** connection head and field transmitter housing may be used by qualified and authorized company and people only, under strict observance of these application manual and relevant standards, legal requirements, and, where appropriate the certificate

Only the empty XD-S... connection head is certified. When used as part of an end product assembly, subsequent approval of the end use equipment assembly is required.

1. VARIETY, MARKS AND COVER - BODY FITING OF XD-S... Series.

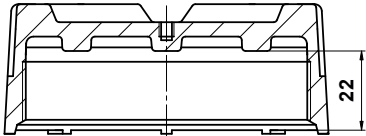
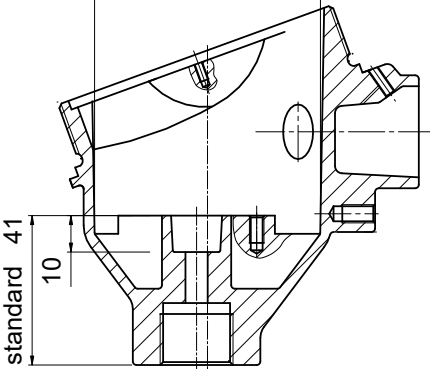
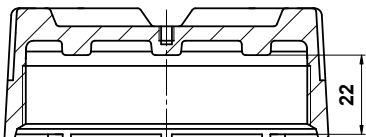
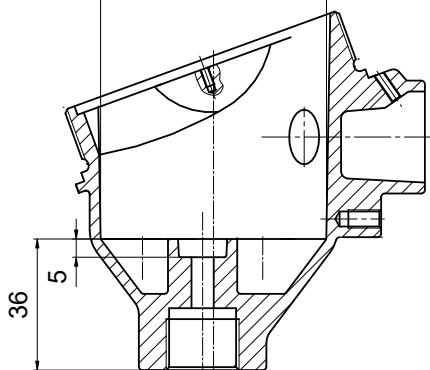
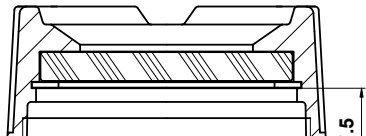
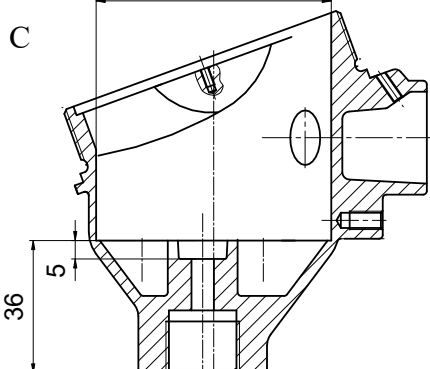
Type of cover	Type of body	Typed of connetion head
<p>1</p>  <p>no letter mark, standard high, blind</p>	<p>A</p> <p>standard Ø62</p>  <p>standard 41 10</p> <p>SD - standard size</p>	<p>1+A → XD-SD</p> <p>1+B → XD-SH</p> <p>1+C → XD-SB</p>
<p>2</p>  <p>EH – Endress+Hauser standard</p>	<p>B</p> <p>standard Ø62</p>  <p>36 5</p> <p>SH – 5mm deeper</p>	<p>2+A → XD-SDEH</p> <p>2+B → XD-SHEH</p> <p>2+C → XD-SBEH</p>
<p>3</p>  <p>win – window cover</p>	<p>C</p> <p>Ø64</p>  <p>36 5</p> <p>SB – 5mm deeper 2mm wide</p>	<p>3+A → XD-SDwin</p> <p>3+B → XD-SHwin</p> <p>3+C → XD-SBwin</p>

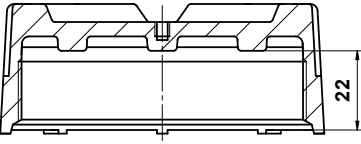
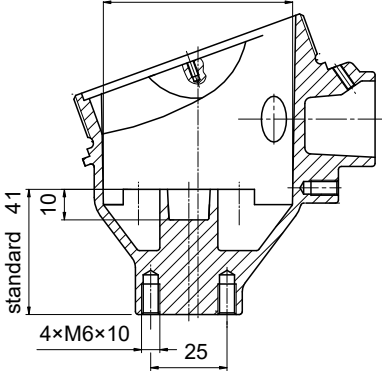
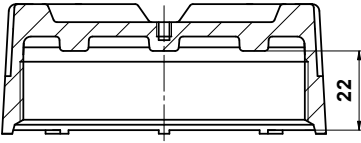
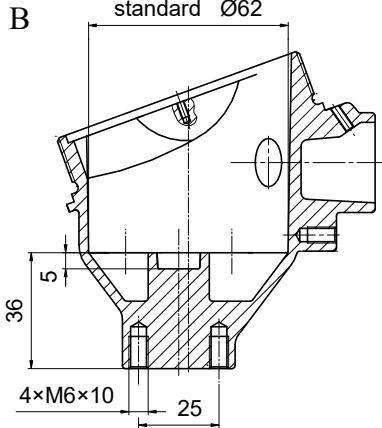
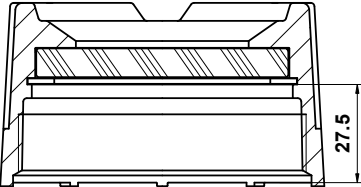
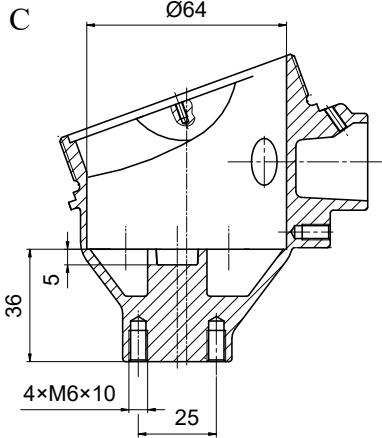
Type of cover	Type of body	Typed of connetion head
<p>1</p>  <p>no letter mark, standard high, blind</p>	<p>A</p> <p>standard Ø62</p> 	<p>1 + A → XD-SDF</p> <p>1 + B → XD-SHF</p> <p>1 + C → XD-SBF</p>
<p>2</p>  <p>EH – Endress+Hauser standard</p>	<p>SDF - standard size</p> <p>B</p> <p>standard Ø62</p> 	<p>2 + A → XD-SDFEH</p> <p>2 + B → XD-SHFEH</p> <p>2 + C → XD-SBFEH</p>
<p>3</p>  <p>win – window cover</p>	<p>SHF - 5 mm deeper</p> <p>C</p> <p>Ø64</p>  <p>SBF - 5 mm deeper 2mm wide</p>	<p>3 + A → XD-SDFwin</p> <p>3 + B → XD-SHFwin</p> <p>3 + C → XD-SBFwin</p>

2. DESTINATION.

Connection heads **XD-S...** and field transmitter housing **XD-S...F...** are foreseen to accommodate head electronic transmitter, DIN spring loaded measuring inserts of temperature sensors and for working in hazardous areas :

Marking:

CCC
Ex db I Mb Ex db IIC Gb Ex tb IIIC Db

Standards:

GB/T 3836.1-2021
 GB/T 3836.2-2021
 GB/T 3836.31-2021

Service temperature

Connection head type	T_{serv}	T_{serv}
	o-ring VQM rubber (silicon)	o-ring FKM rubber
XD-SD... series	-50 to +150 °C	-20 to +200 ° C
XD-SD...win series	-50 to + 85 °C	-20 to 85 °C

Possible zone application

Zone	Protection Code
Zone 1 , Zone 21	Ex d
Zone 2 , Zone 22	Ex d

3. FLAMEPROOF JOINTS.

There are three flameproof joints in XD-S... connection head:

1. on the cover thread **M80×1,5 6H**
2. **D₂, D₃** on the conduit openings for cable gland, threaded holes : M20x1.5, ½NPTmod, ¾NPTmod.
3. **D₁/d₁** on process opening for thermowell :
 - **d₁** cylindrical smooth standard hole ø6.1H8, ø8^{+0.1}_{+0.02}, ø8.1H8, ø9.6H8, ø10^{+0.1}_{+0.02}, ø10.1H7, ø12.1H7 ø12.8H7, ø15.1H7 for arrange flameproof joint with sensor measuring insert,
 - **d₁** = ø13 mm cylindrical smooth opening hole for sensor wires (non flameproof),
 - **d₁** cylindrical smooth hole ø6.1H8, ø6^{+0.04}_{-0.05}, ø8^{+0.1}_{+0.02}, ø8.1H8, ø9.6H8, ø10.1H7 in screw bush,
 - **d₁** = M16x1.5 6H for creating flameproof joints with screw bush (without screw bush)
 - **D₁** threaded holes : M20x1.5 , M24x1.5 , M27x2, ½NPTmod, ¾NPT mod, Rc½, Rc¾, BSPT½, BSPT ¾.
 - **D₁** threaded holes: G½, G¾, G¾, BSPP½, BSPP¾, BSPP¾ (non flameproof).

All three flameproof joints are designed for:

- volume $100 < V \leq 500 \text{ cm}^3$
- group IIC enclosures

Metric threaded joints: cover thread and D ₁ , D ₂ , D ₃ and screw bush		
Standard EN 60079-1 requirements	Achieved value	
• pitch: ≥ 0.7 mm	cover	1.5 mm
	D ₁ , D ₂ , D ₃	1.5 mm or 2 mm
	d ₁ = M16×1,5	1.5 mm
• threads form and quality of fit: medium or fine tolerance quality according to ISO 965-1 and ISO 965-3	cover	6H/6g
	D ₁ , D ₂ , D ₃	6H 6g of male thread should be ensured by customer
	d ₁ = M16×1,5	6H 6g of screw bush should be ensured by customer
• threads engaged: ≥ 5	cover	9.5
	D ₁ , D ₂ , D ₃	should be ensured by customer, possible to reach: 9 or 7
	d ₁ = M16×1,5	should be ensured by customer, possible to reach: 13
• depth of engagement: ≥ 8 mm	in cover	14.5 mm
	D ₁ , D ₂ , D ₃	should be ensured by customer, possible to reach: 14 mm
	d ₁ = M16×1,5	should be ensured by customer, possible to reach: 20 mm

Cylindrical joint: d_1	
Standard EN 60079-1 requirements	Achieved value
• Minimum width of joint : 12.5 mm	13.5 mm
• Maximum gap: 0.15 mm	depend on OD sensor (bush) insert applied by customer

Rc, BSPT Taper threaded joint: D_1	
Standard EN 60079-1 requirements	Achieved value
• threads provided on each parts: ≥ 5	possible to reach: 8 full thread male part should be ensured by customer

NPT threaded joints: D_1 , D_2 , D_3	
Standard EN 60079-1 requirements	Achieved value
• pitch : ≥ 0.9 mm	1.814 mm
• threads provided on each parts: ≥ 6	7.5
• threads engaged: ≥ 5	6 (handtight) 7 (wrenchtight)
Standard Pipeline taper threads which meet above requirements must be modified. The way of modification is described in Annex for OIT-17/03	

4. FLAMEPROOF JOINTS ON D_1 / d_1 HOLES.

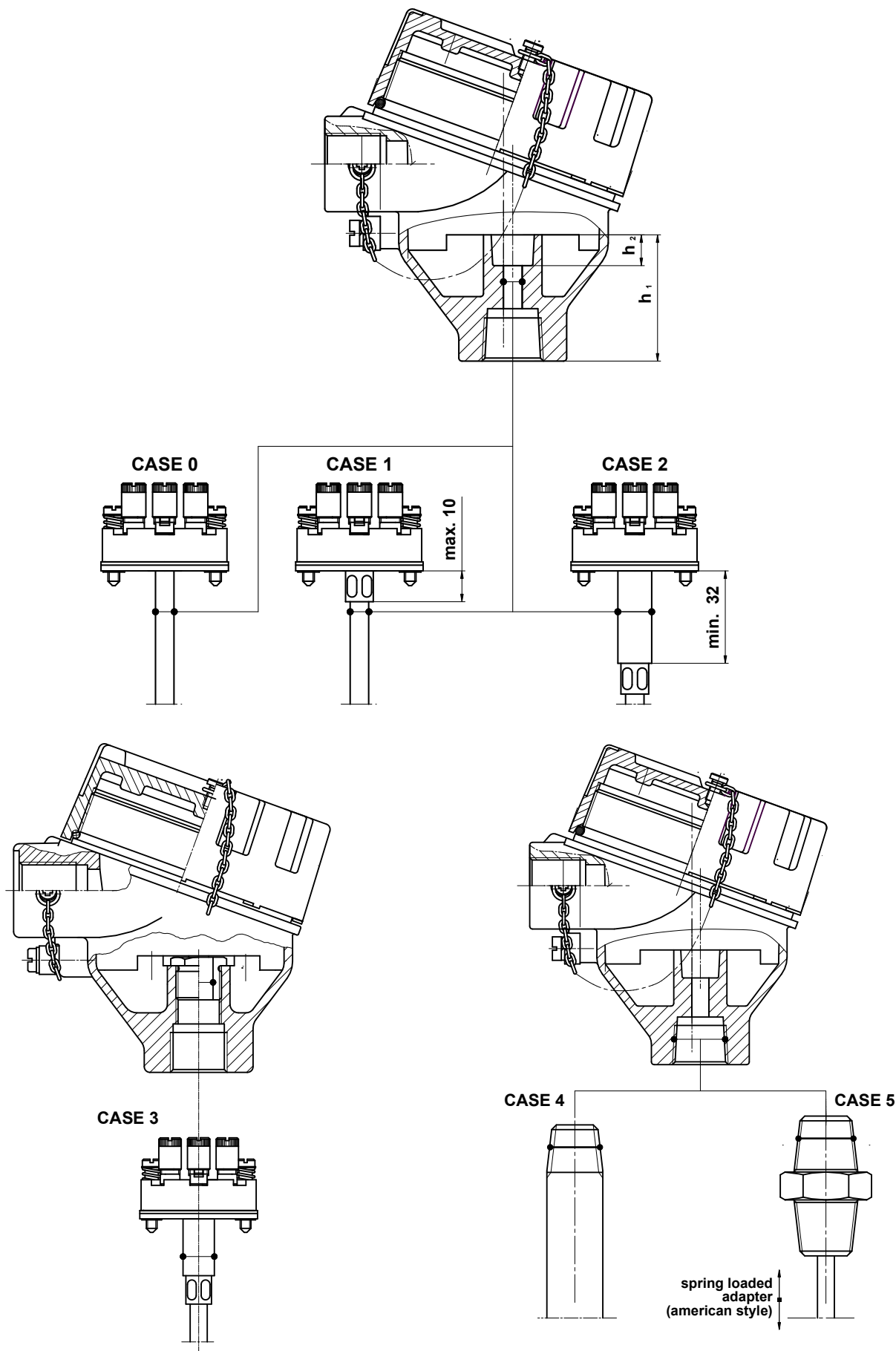

a). FLAMEPROOF JOINT IN THE PROCESS OPENING: D₁, d₁, for XD-SD... Series CONNECTION HEADS.

Dimension of the thread D₁ and hole d₁ are given in the table below.

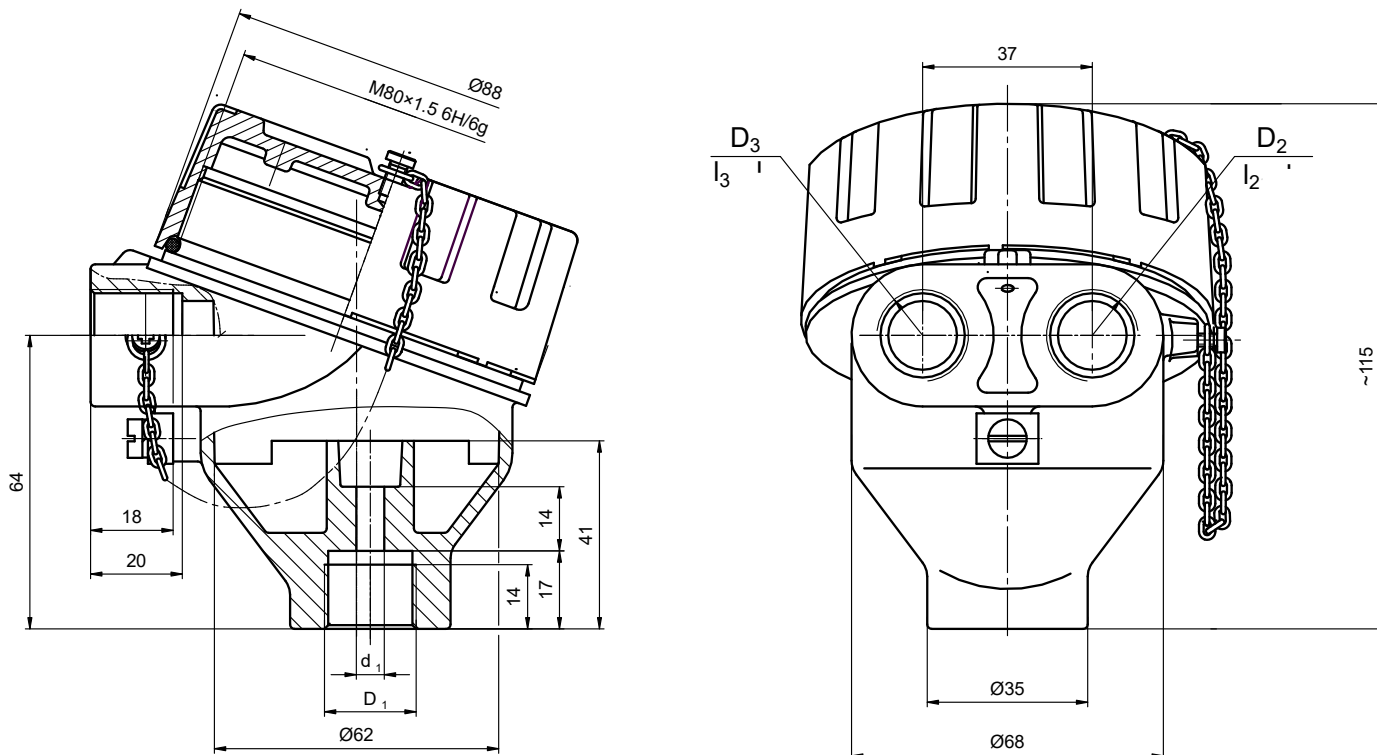

B O D Y			
D₁ ([mm])	Destination	d₁ ([mm])	Destination
M20x1.5 M24x1.5 M27x2 ½NPT _{mod} ¾NPT _{mod} Rc½ Rc¾ BSPT ½ BSPT ¾	all these threads are foreseen to create flameproof joint with male threads of at thermowells, or male thread of spring loaded adapter (American style) CASE 4, 5	Ø 6.1 H8 Ø 8 ^{+0.1} / _{+0.02} Ø 8.1 H8 Ø 9.6 H8 Ø 10 ^{+0.1} / _{+0.02} Ø 10.1 H7 Ø 12.8 H7	all these smooth hole are foreseen to create flameproof joint with suitable tolerated sheath of mineral insulated cable of spring loaded sensor (DIN style) CASE 1
G½, G¾, G¾ BSPP½, BSPP¾, BSPP¾ and other on request	CASE 0, 1, 2 hole d1 must be flameproof (for arrange flameproof joint with sensor measuring insert)	Ø 13 and other on request	Does not foresee to create flameproof joint – sensor wires opening only. CASE 4, 5

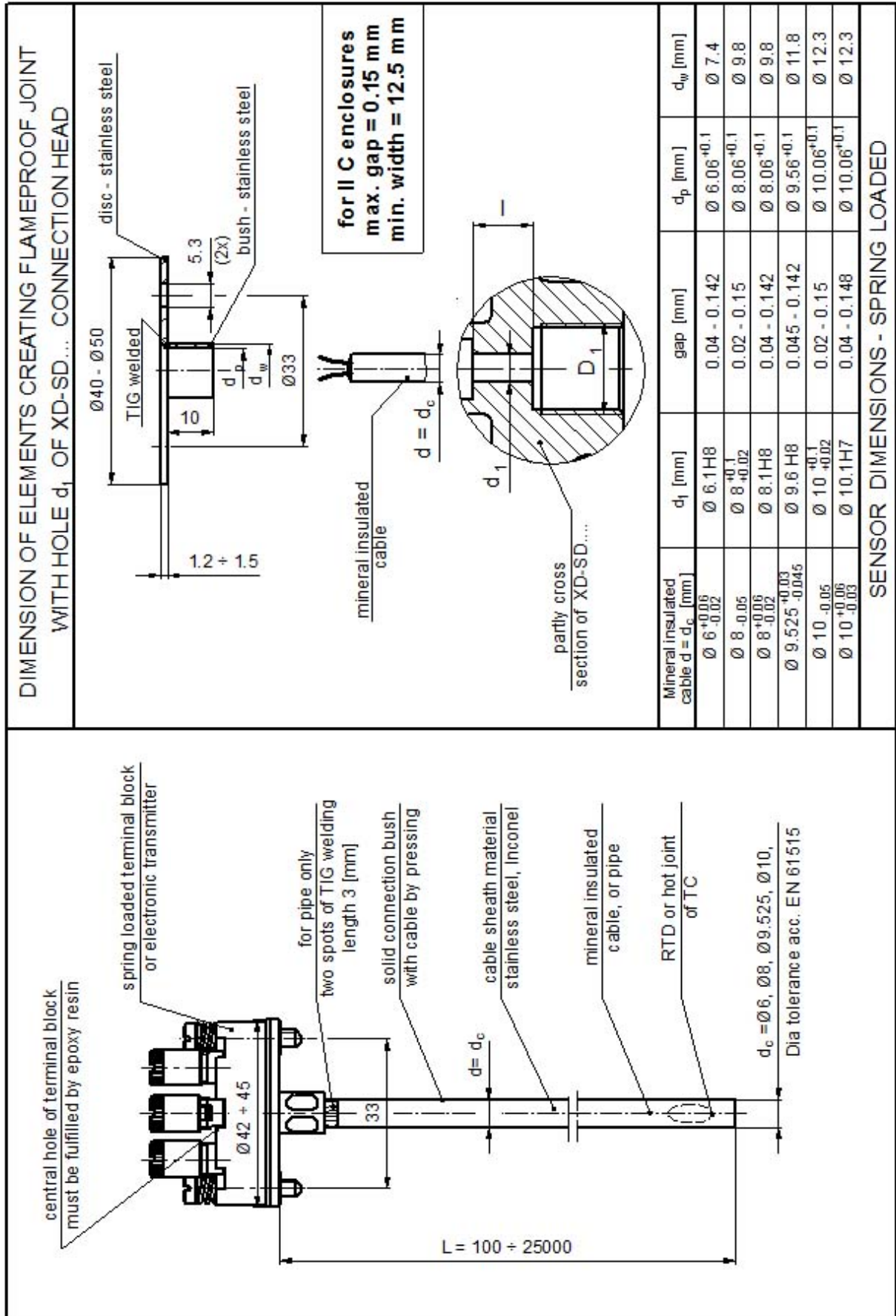

b). FLAMEPROOF JOINT IN THE PROCESS OPENING: D₁, d₁, for XD-SD Series CONNECTION HEADS.

Dimension of the thread D₁ and hole d₁ are given in the table below.

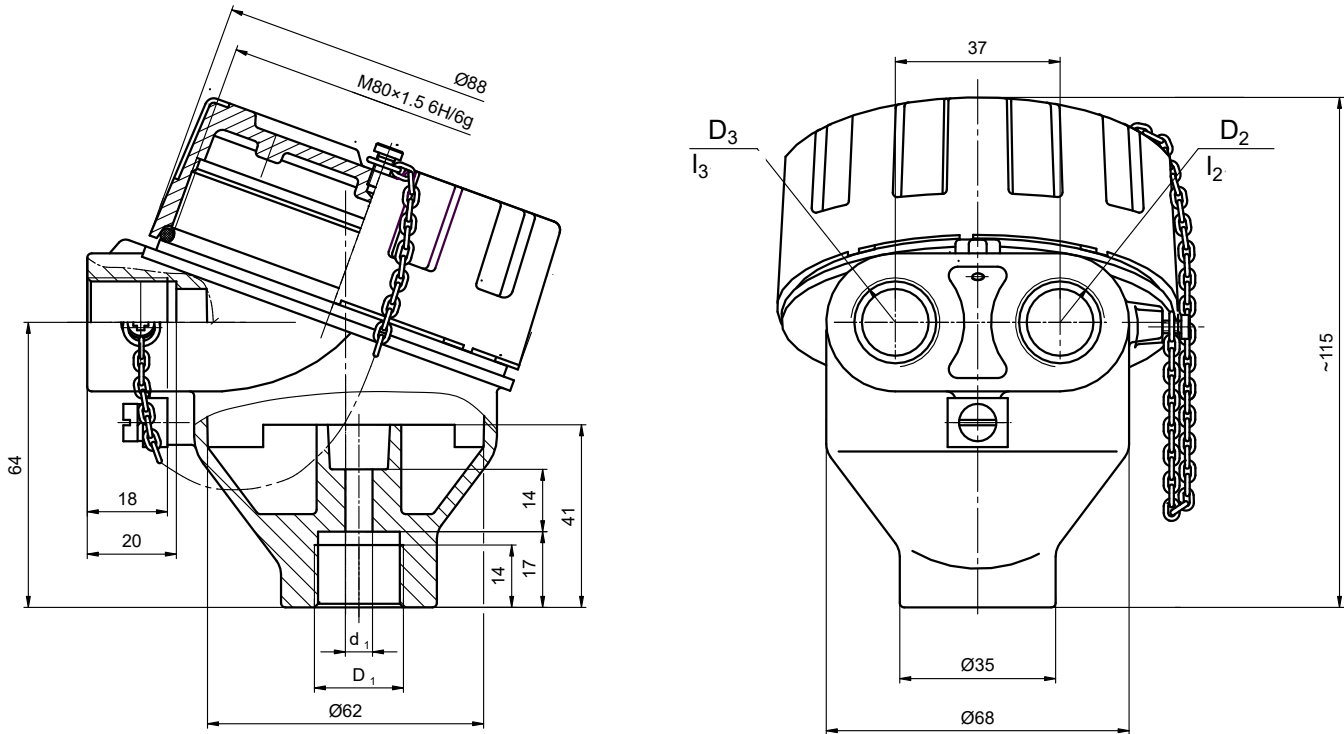

B O D Y			
D₁ ([mm])	Destination	d₁ ([mm])	Destination
M20x1.5 M24x1.5 M27x2 ½ NPT _{mod} ¾ NPT _{mod} Rc½ Rc¾ BSPT ½ BSPT ¾	all these threads are foreseen to create flameproof joint with male threads of at thermowells, or male thread of spring loaded adapter (American style) CASE 4, 5	Ø 6.1 H8 Ø 8 ^{+0.1} / _{+0.02} Ø 8.1 H8 Ø 10 ^{+0.1} / _{+0.02} Ø 10.1 H7 Ø 12.1 H7 Ø 15.1 H7	all these smooth hole are foreseen to create flameproof joint with suitable tolerated sheath of mineral insulated cable of spring loaded sensor (DIN style) CASE 2
G½, G¾, G¾ BSPP½, BSPP¾, BSPP¾ and other on request	CASE 0, 1, 2 hole d1 must be flameproof (for arrange flameproof joint with sensor measuring insert)	Ø 13 and other on request	does not foresee to create flameproof joint – sensor wires opening only. CASE 4, 5

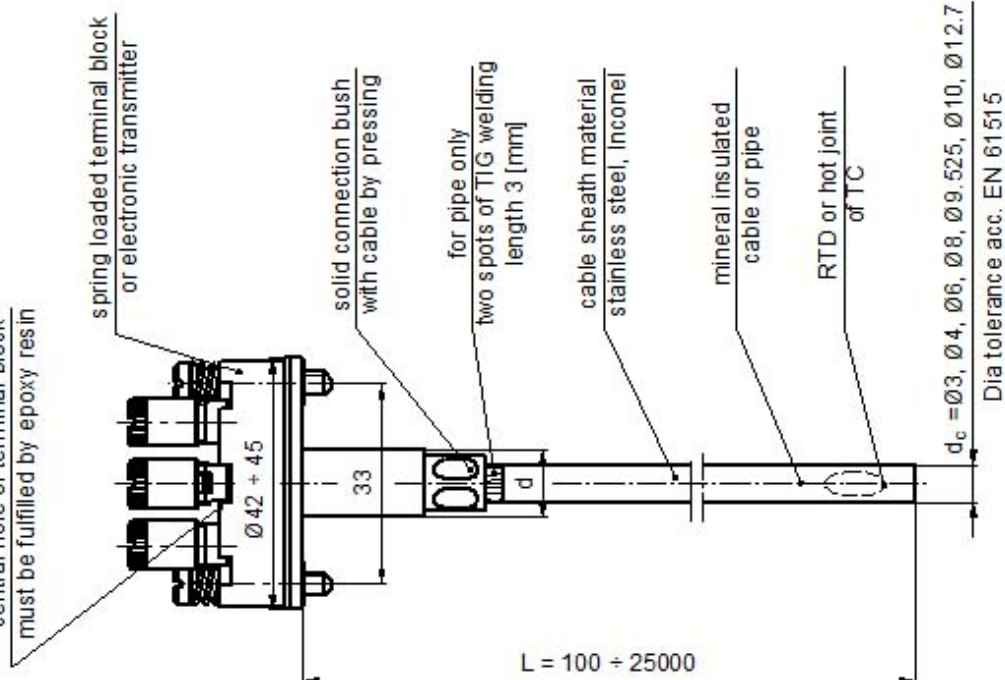
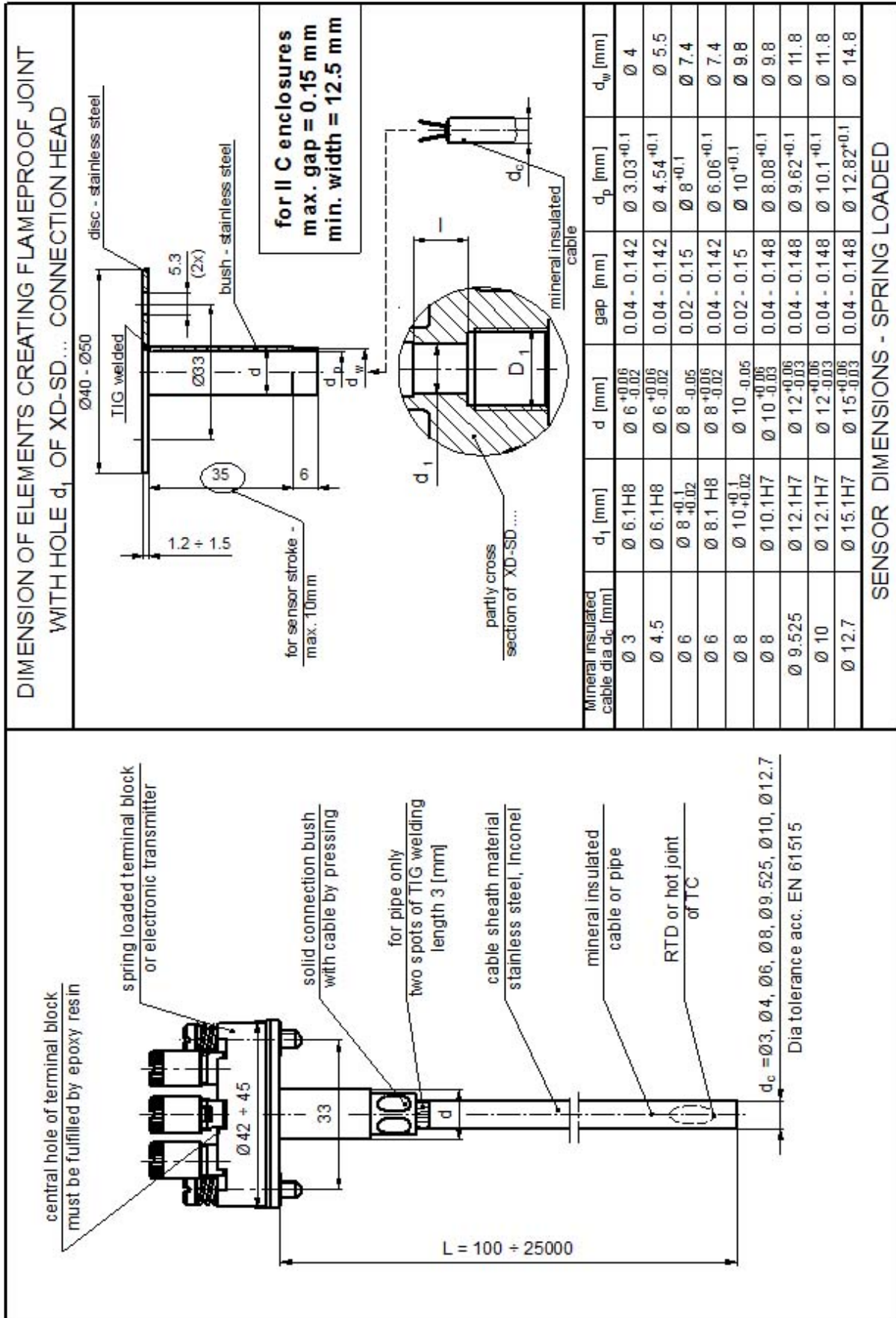

c). FLAMEPROOF JOINT IN THE PROCESS OPENING: D₁, d₁ for XD-SD, XD-SDwin CONNECTION HEAD

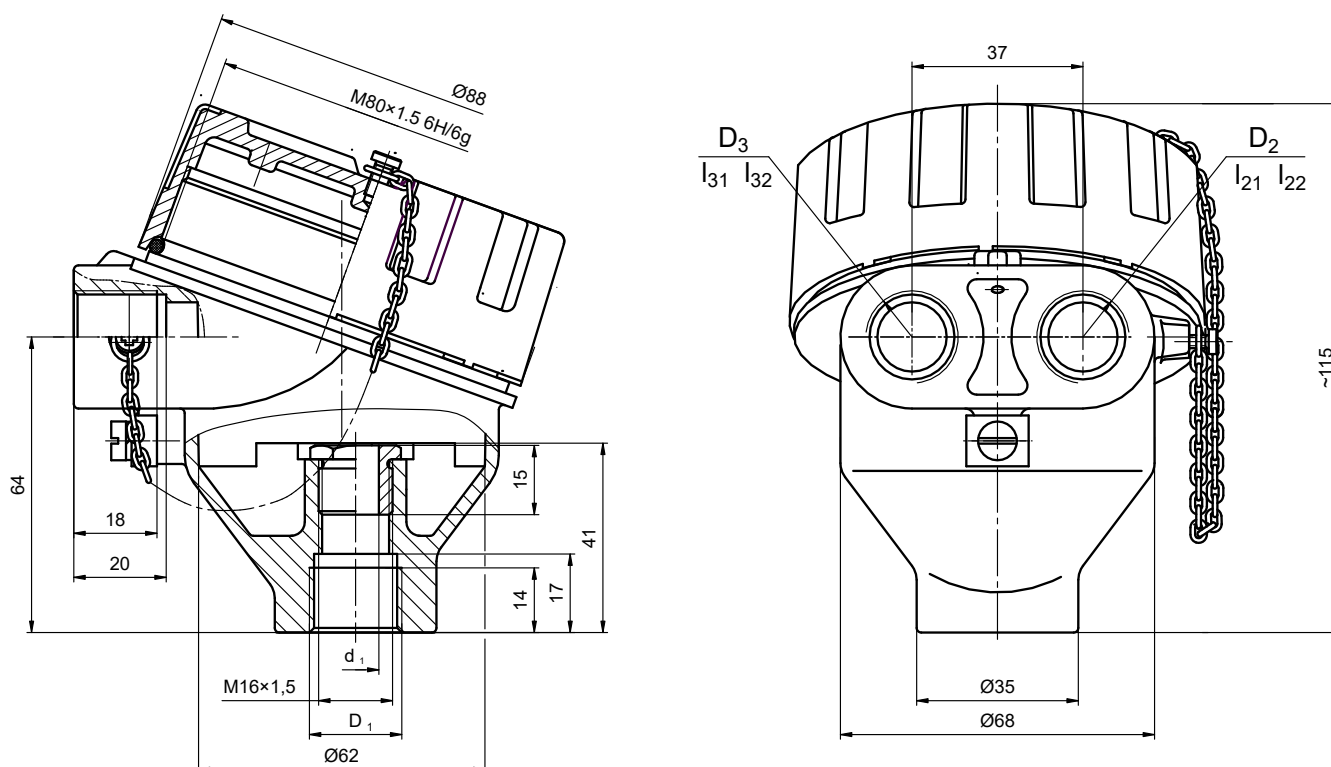

B O D Y			
D₁ ([mm])	Destination	d₁ ([mm])	Destination
M20x1.5 M24x1.5 M27x2 ½NPT _{mod} ¾NPT _{mod} Rc½ Rc¾ BSPT ½ BSPT ¾	all these threads are foreseen to create flameproof joint with male threads of at thermowells, or male thread of spring loaded adapter (American style) CASE 4, 5	Ø 6 ^{+0,04} _{-0,05} Ø 6.1 H8 Ø 8 ^{+0,1} _{+0,02} Ø 8.1 H8 Ø 10 ^{+0,1} _{+0,02} Ø 10.1 H7	all these smooth hole in the screw bush are foreseen to create flameproof joint with suitable tolerated OD of a bush of spring loaded mineral insulated cable (DIN style) CASE 3
G½, G¾, G¾ BSPP½, BSPP¾, BSPP¾ and other on request	CASE 0, 1, 2 hole d1 must be flameproof (for arrange flameproof joint with sensor measuring insert)	M16x1.5	is foreseen to create flameproof joint with screw bush, or without screwed bush screw can be used as opening for sensor wires

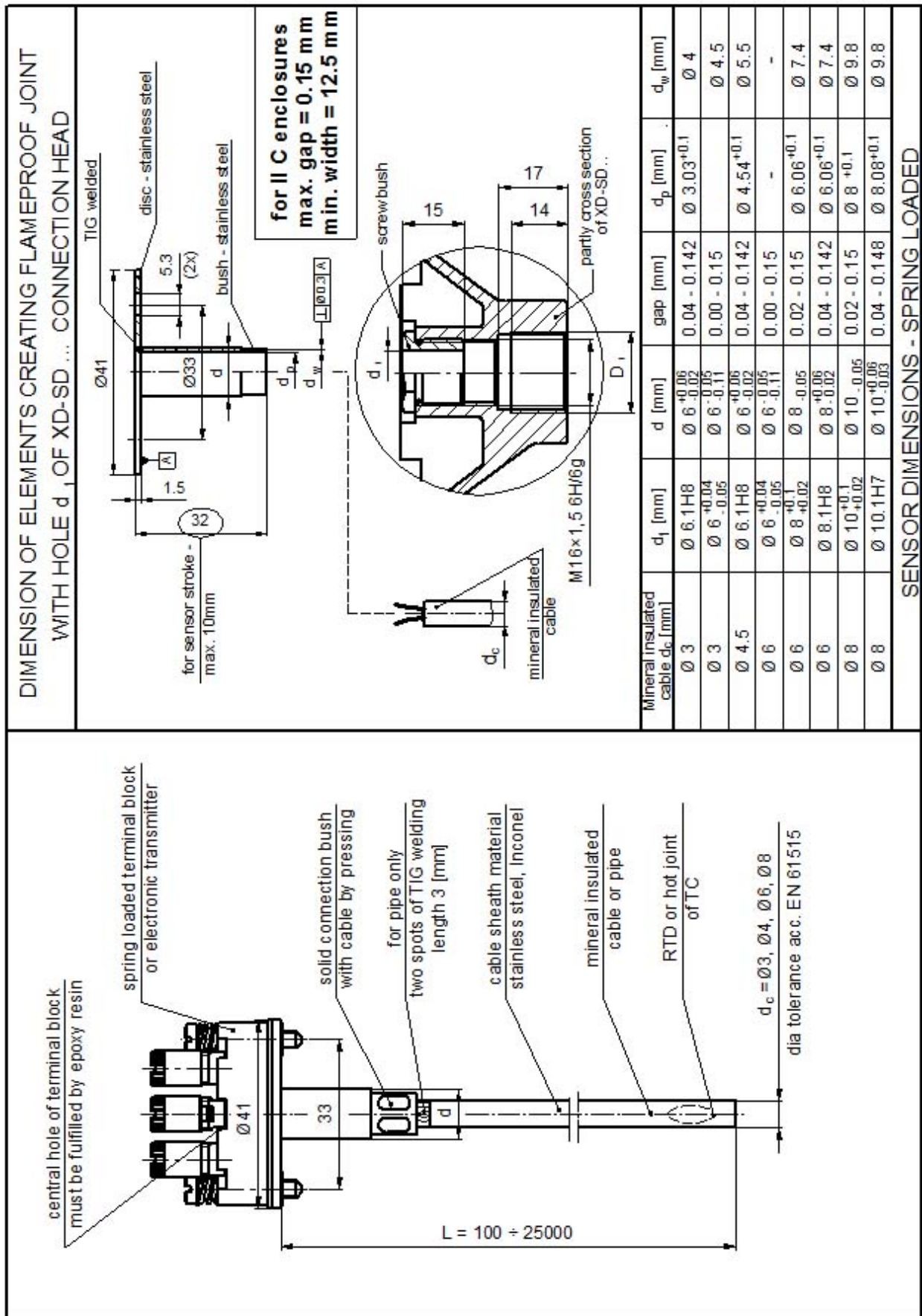

d). FLAMEPROOF JOINT IN THE PROCESS OPENING: D₁, d₁ for XD-SH..., XD-SB Series CONNECTION HEADS.

Dimension of the thread D₁ and hole d₁ are given in the table below.

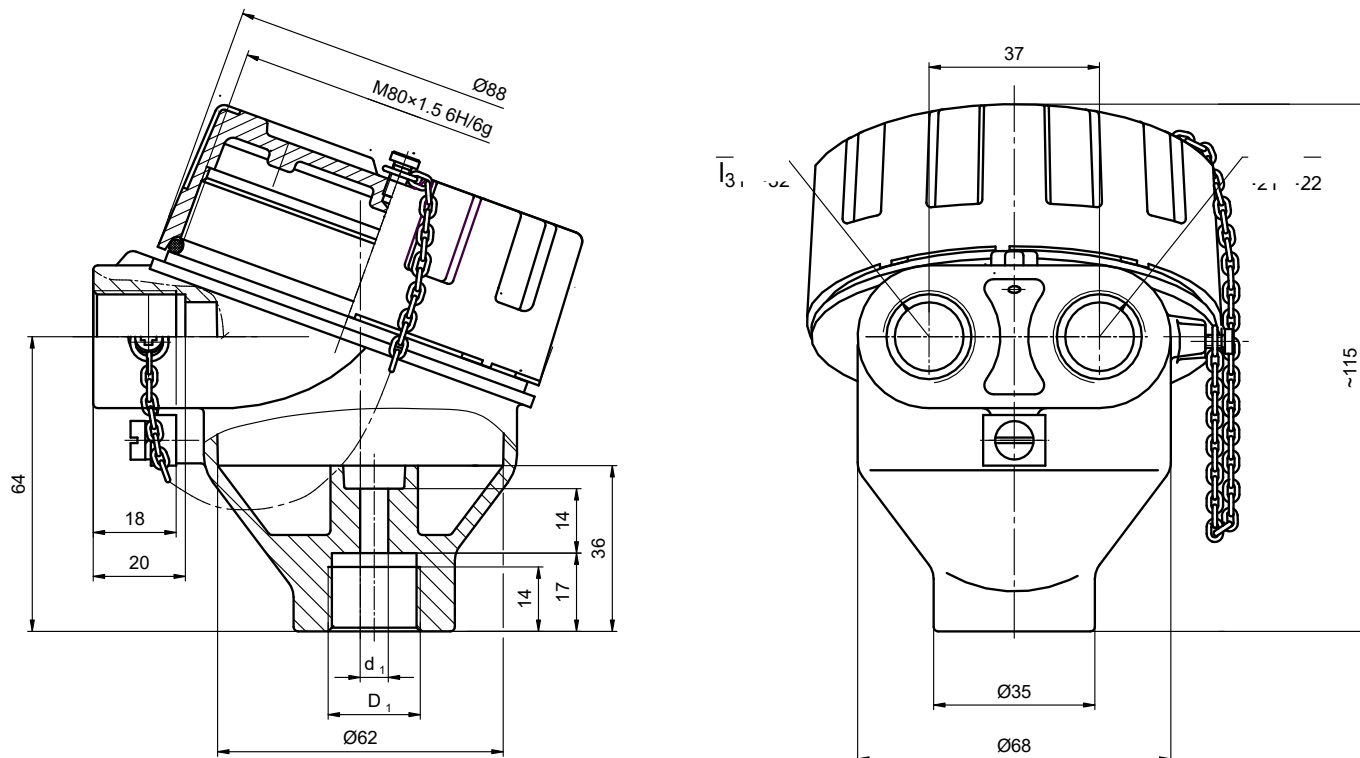

B O D Y			
D₁ ([mm])	Destination	d₁ ([mm])	Destination
M20x1.5 M24x1.5 M27x2 ½NPT _{mod} ¾NPT _{mod} Rc½ Rc¾ BSPT ½ BSPT ¾	all these threads are foreseen to create flameproof joint with male threads of at thermowells, or male thread of spring loaded adapter (american style) CASE 4, 5	Ø 6.1 H8 Ø 8 ^{+0.1} / _{+0.02} Ø 8.1 H8 Ø 9.6 H8 Ø 10 ^{+0.1} / _{+0.02} Ø 10.1 H7 Ø 12.8 H7	all these smooth hole are foreseen to create flameproof joint with suitable tolerated sheath of mineral insulated cable of spring loaded sensor (DIN style) CASE 0
G½, G¾, G¾ BSPP½, BSPP¾, BSPP¾ and other on request	CASE 0, 1, 2 hole d1 must be flameproof (for arrange flameproof joint with sensor measuring insert)	Ø 13 and other on request	Does not foresee to create flameproof joint – sensor wires opening only. CASE 4, 5

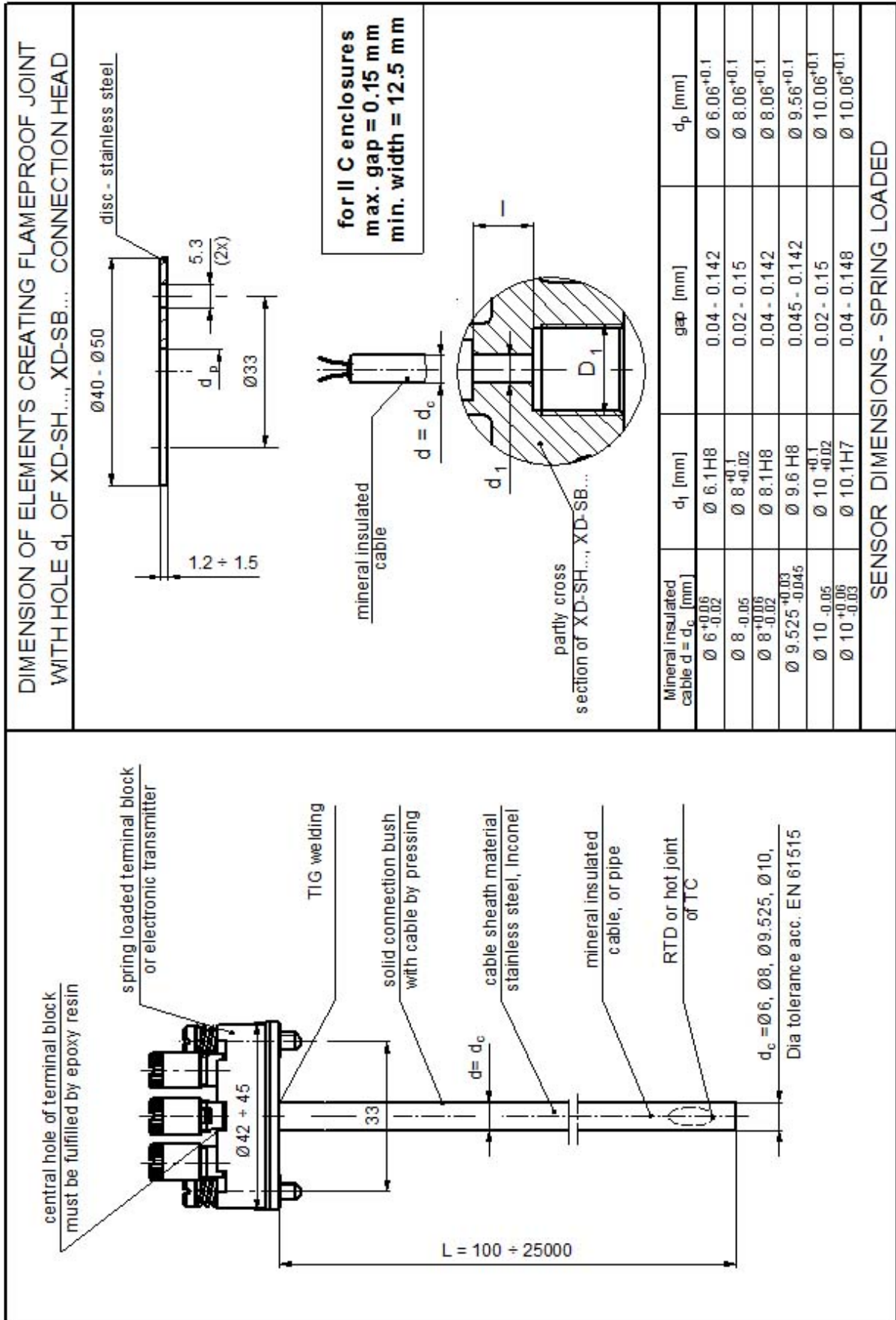

5. CARRIED OUT TESTS

a) FOR NON TRANSMISSION of an INTERNAL IGNITION

	Process holes	CASE	EN 60079-1 p. 15.2.2.1 test
d₁	process holes in the body Ø 6.1 H8 Ø 8.1 H8 Ø 9.6 H8 Ø 10.1 H7	0, 1, 2	Case *
	Ø 12.8 H7 Ø 15.1 H7	2	
	Ø 13 other on request	4, 5	does not foresee to create flameproof joint
	process holes in the screw bush Ø 6 ^{+0.04} _{-0.05} Ø 6.1 H8 Ø 8 ^{+0.1} Ø 8.1 ^{+0.02} H8 Ø 10 ^{+0.1} Ø 10.1 ^{+0.02} H7	3	Case *
	M16x1.5	-	is foreseen to create flameproof joint with screw bush, or without screwed bush. Bush screw can be used as opening for sensor wires
D₁	M20x1.5 M24x1.5 M27x2 ½NPT _{mod} ¾NPT _{mod} Rc½ Rc¾ BSPT ½ BSPT ¾	4, 5	Case **
	G½, G¾, G⅜ BSPP½, BSPP¾, BSPP⅜ and other on request	0, 1, 2	Case ***

* in this case thread **D₁** and its connection need not be flameproof (for arrange flameproof joint with sensor measuring insert),

** in this case hole **d₁** need not be flameproof,

*** in this case hole **d₁** must be flameproof (for arrange flameproof joint with sensor measuring insert) . Flameproof possible only for gas.

For Ex tb – dust (for thread **D₁**) require certification of the complete equipment.

mod = modified to meet standards: EN 60079-1, IEC 60079-1, FM 3615, CSA C22.2 No. 0.5,

! Attention !

If other dimension d_1 will be made, or d_1 hole is not used to create flameproof joint, sensor assembler must submit complete device design to notify body for estimating design and eventually for conducting additional tests.

In case of resign d_1 hole to build flameproof joint , D_1 thread and fixed to it threaded male part must create flameproof joint.
 Diameter d_1 hole can be changed on request.

In field transmitter housing XD-S...F..., holes D_1 , d_1 are closed.

b) OVERPRESSURE TEST

According to EN 60079-1

It was carried out tests:

- 4 times reference pressure,
- at maximum water pressure 100 bar no routine test is required when reference pressure of final assembly (XD-S... with additional volume come from thermowell, conduit, pipe, etc.) is no higher than 25 bar.

6. CONDUIT OPENINGS: D_2 , D_3 .

Connection head is adopted to be equipped with various certificated Ex d explosionproof: cable glands, fill sealing fittings or flexible couplings.

7. TEMPERATURE CLASSES, AMBIENT TEMPERATURE, MAX. POWER DISSIPATION.

Max. power dissipation (W)				
Tserv	Temperature class T6 85°C	Pztr (W)		
		For all variety of enclosures position orizontally/vertically	Temperature class T5 100°C	
		Pztr (W)		
		For all variety of enclosures position horizontally/vertically		
40 °C	$\Delta\theta \leq 40$ K	8,0 / 9,0	$\Delta\theta \leq 55$ K	12,0 / 13,0
55°C	$\Delta\theta \leq 25$ K	4,3 / 4,7	$\Delta\theta \leq 40$ K	8,0 / 9,0
70°C	$\Delta\theta \leq 10$ K	1,4 / 1,45	$\Delta\theta \leq 25$ K	4,3 / 4,7
85°C	N.A.	-- / --	$\Delta\theta \leq 10$ K	1,4 / 1,45

Notice: Max. admissible temperature is always 5°C lower than the temperature of temperature class.

8. EARTH AND PROTECTION TERMINALS.

These terminals can be connected with both solid wire and stranded wire cables as shown in the table below .

Place	Type	Cable cross section [mm ²]	
		stranded wire	solid wire
Inside	Protection terminal	1.5	2.5*
Outside	Earth terminal	4.0	6.0

* Due to the thickness of the wire used, some variants require the use of a suitable (dedicated) wire terminal - connector.

9. SIZE OF THE INTERNAL SPACE OF XD-S... Series CONNECTION HEAD WITHOUT THE REGARD OF THE AXIAL MOVEMENT 8mm OF THE MEASURING INSERT.

DIMENSIONS [mm]

TYPE	standard dim. of transmitter $\phi \times h$	max. dim. of transmitter $\phi \times h$	h_1	h_2	CASE OF APPLICATION
XD-SD	42 x 42	58 x 35	41	10	0, 1, 2, 4, 5
XD-SH	42 x 47	58 x 40	36	5	0, 2, 4, 5
XD-SB	42 x 47	60 x 39	36	5	0, 2, 4, 5
XD-SDdia ¹⁾	42 x 30	58 x 23	41	10	0, 1, 2, 4, 5
XD-SHdia ¹⁾	42 x 35	58 x 28	36	5	0, 2, 4, 5
XD-SBdia ¹⁾	42 x 35	60 x 27	36	5	0, 2, 4, 5
XD-SDdig ²⁾	42 x 21	58 x 14	41	10	0, 1, 2, 4, 5
XD-SHdig ²⁾	42 x 26	58 x 19	36	5	0, 2, 4, 5
XD-SBdig ²⁾	42 x 26	60 x 18	36	5	0, 2, 4, 5
XD-SDEH	42 x 42	58 x 35	41	10	0, 1, 2, 4, 5
XD-SHEH	42 x 47	58 x 40	36	5	0, 2, 4, 5
XD-SBEH	42 x 47	60 x 39	36	5	0, 2, 4, 5

1) XD-S...win + loop power indicator ST0028

2) XD-S...win + loop power indicator LPI-02

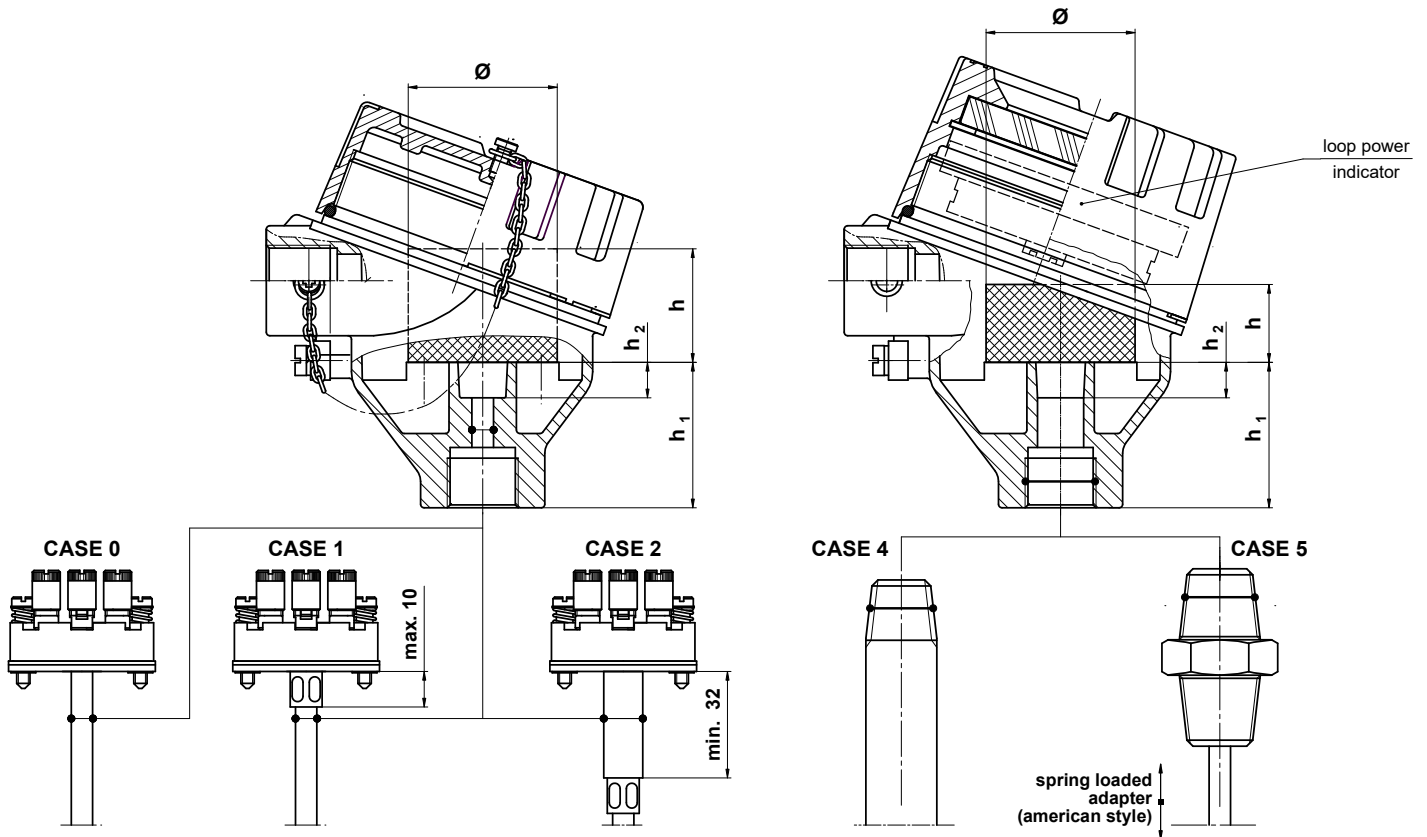

10. PROTECTION DEGREE.

There are three places which decide of IP degree.

1
LIMATHERM RESPONSIBILITY
- design
- execution quality
CUSTOMER RESPONSIBILITY
- rate of screw tightness
- max. possible to achieve IP 68

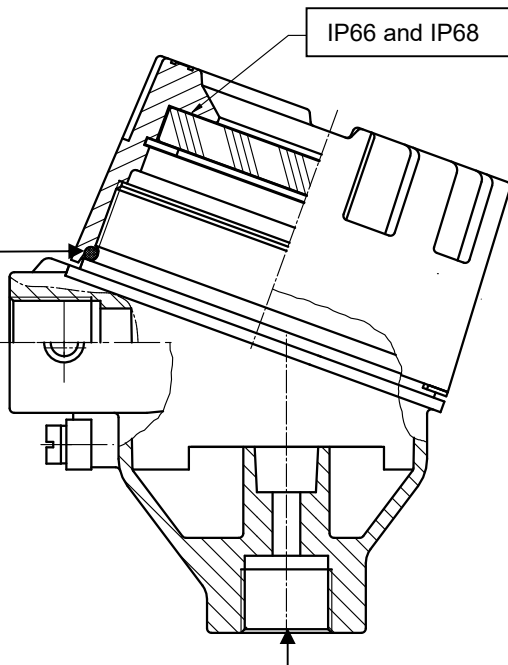
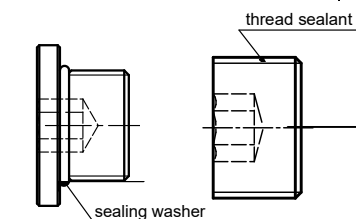
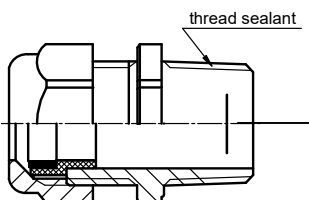
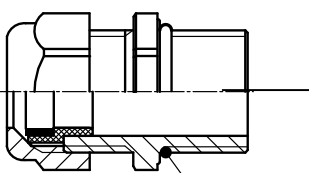

3
LIMATHERM RESPONSIBILITY
- thread execution quality
CUSTOMER RESPONSIBILITY
- choosing of connection head type
- thermowell connection
- connection head – thermowell sealing

2
LIMATHERM RESPONSIBILITY
- sealing surface quality
CUSTOMER RESPONSIBILITY
- choosing of cable gland type with regard to IP degree
- cable gland mounting and sealing quality: for IP66÷ IP68 taper threads must be sealed by thread sealant;
- for IP66÷ IP68 parallel threads must be sealed by nylon or red fibre sealing washer
- choosing of cable diameter with regards to producer requirements on required by its producer
- rate of press cap tightness
- max. possible to achieve IP66 ÷ IP68
- plugged IP68

TIGHTEN TYPE	DESCRIPTION OF THE SOLUTION	PROTECTION DEGREE
<p>body</p> <p>thread</p> <p>tube</p>	<p>1. Parallel and taper thread are manufactured in the standard accuracy class of manufacturing.</p> <p>2. No gasket, no packing with any packing agent.</p> <p>Threads are additionally packed with use of – for example – LOCTITE 577 agent.</p>	IP 54
<p>body of the connection head</p> <p>rubber gasket</p> <p>collar of protection tube</p> <p>press cap</p> <p>protection tube</p>	<p>Tube with a pressing flange for rubber gasket to be pressed to the head, and with a cap.</p>	IP 66÷68
XD-SDF XD-SDFwin	closed	IP 66÷68

Protection degree for elements			Total protection degree Possible to achieve
1	2	3	
IP 68	IP 66	IP 54	IP 54
IP 68	IP 66	IP 68	IP 66
IP 68	IP 67	IP 68	IP 67
IP 68	IP 68	IP 68	IP 68

! ATTENTION !

Protection IP68 refers to depth 1,0m of submersion under water.

It is required min IP65 protection for instruments designed for dust zones.

(Besides zone 22, non-conductive dust, where min IP54 protection is required)

11. COVER LOCKING.

Cover is locked by screw with hex socket using hex spanner with across flat 2mm. This screw is situated in cavity between two conduit opening's bosses.

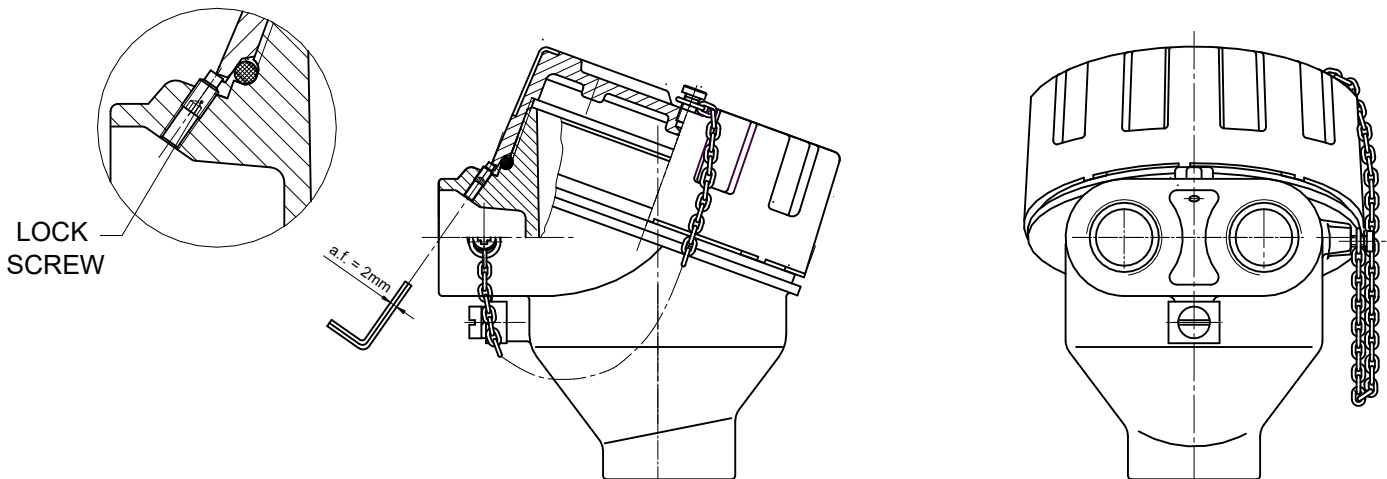

12. WAY OF FIXING FIELD TRANSMITTER HOUSING TO THE WALL AND THE PIPE.

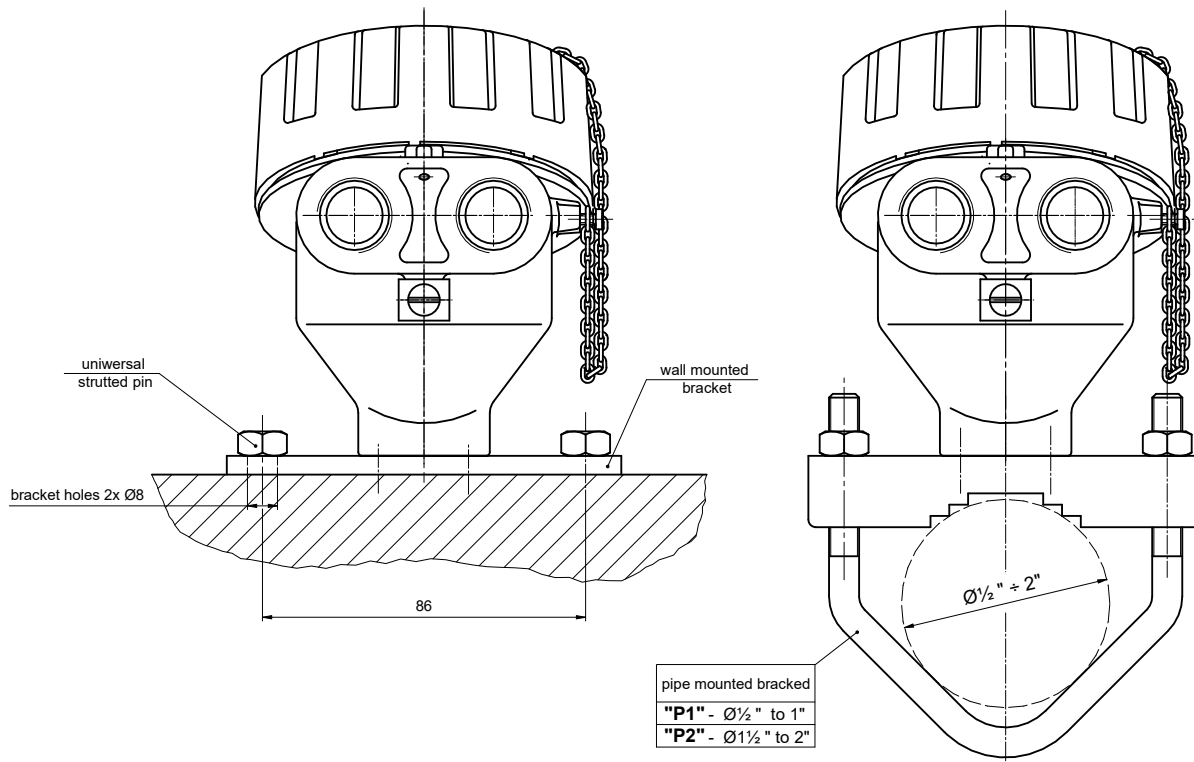

13. MARKING.

According to standards:

- GB/T 3836.1-2021
- GB/T 3836.2-2021
- GB/T 3836.31-2021

Example of marking of the XD-S... is as follow:

LIMATHERM COMPONENTS, 41-506 CHORZÓW POLAND

壳体

Ex db I Mb; Ex db IIC Gb; Ex tb IIIC Db;

型号 : XD-SD



Places for labels

