

MOUNTING BRACKET - type UZ 21

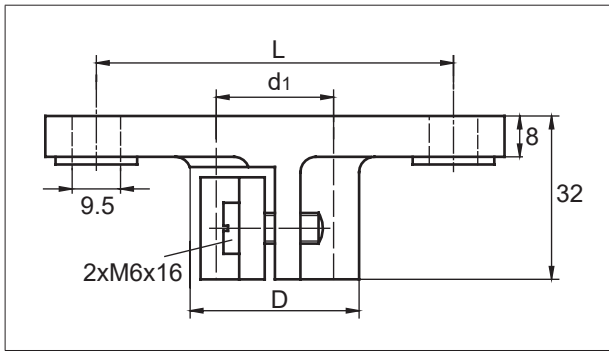

TYPE	DIAMETER OF CLAMPING PIPE d [mm]	DIMENSIONS [mm]		
		d ₁	D	L
UZ 21-15	Ø15	16	27	55
UZ 21-22	Ø22	23	33	70
UZ 21-26-29	Ø26+Ø29	29	39	70
UZ 21-32	Ø32	33	39	70
Material	cast steel, black powder lacquer coating			
Max temp.	300°C			
Gas tightness	non tightness			
Ordering sample: Mounting bracket UZ 21-22				

MOUNTING BRACKET FOR WELDING - type UZ 11

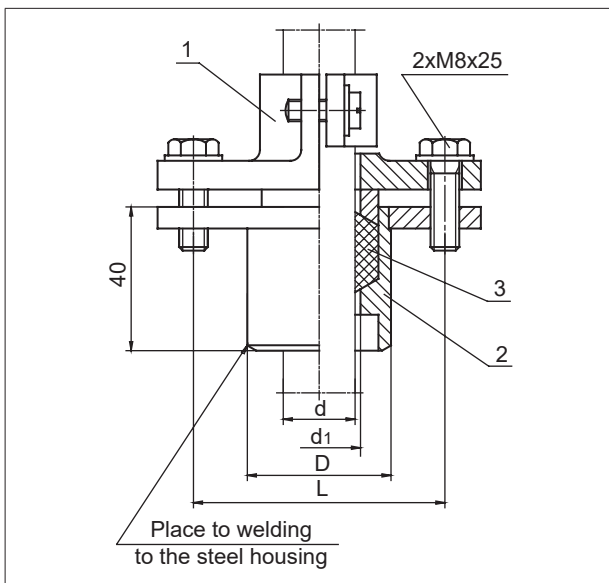

TYPE	DIAMETER OF CLAMPING PIPE d [mm]	DIMENSION [mm]		
		d ₁	D	L
UZ 11-15	Ø15	16	35	55
UZ 11-22	Ø22	23	40	70
UZ 11-32	Ø32	33	50	70
Materials	1. Cast steel, black powder lacquer coating. 2. Carbon steel ST30, black powder lacquer coating. 3. Ceramic packing cord or teflon ring.			
Max temp.	300°C			
Gas tightness	to 1 bar (300°C)			
Ordering sample: Mounting bracket UZ 11-15				

COMPRESSION FITTING - type UG 1

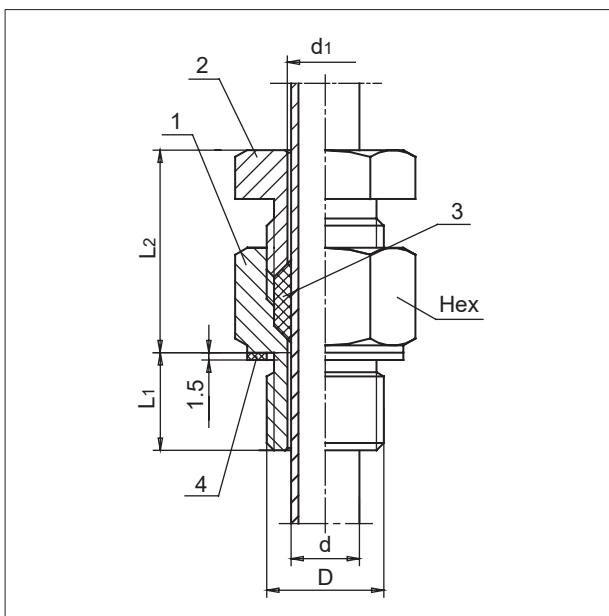

TYPE	DIAMETER OF SHEATH d [mm]	TYPE OF THREAD D	DIMENSIONS [mm]			
			d ₁	Hex	L ₁	L ₂
UG 1-6	Ø6	M16×1.5	Ø6.5	22	16	~ 32
		M18×1.5		27	20	
UG 1-8	Ø8	G½	Ø8.5	22	16	~ 34
		M20×1.5		27	20	
UG 1-12	Ø12	G¾	Ø12.5	32	20	~ 35
		M24×1.5		32	20	
UG 1-15	Ø15	G½	Ø15.5	41	25	~ 42
		G1		41	25	
UG 1-20	Ø20	M30×2	Ø20.5	41	25	~ 42
UG 1-22	Ø22	G1	Ø22.5			
Materials of elements	1. Steel 1.071x zinc-plated. 2. Steel 1.071x zinc-plated. 3. Ceramic packing cord. 4. BELPA (non asbestos)					
Max temperature	300°C					
Gas tightness	to 1 bar					
Ordering sample: Compression fitting UG1-15-M24×1.5						